

Scale,	1:16	Name	Poschen
edited,	28.07.	Date	2014
tested		Norm.	
Drahting-no			
637-1400-07/01			



Abstreifsysteme & Förderbandzubehör

Elastol-Hartmetall-Segmentabstreifer NEU mit Federn

Technische Änderungen vorbehalten
technical changes reserved

Art.Nr. 1400E37-FE

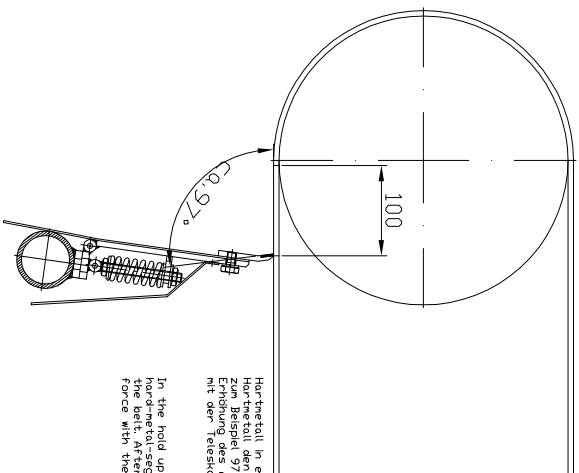

Hor-thetall in eine Position bringen wo das Hor-thetall den Gurt berührt.
 Zum Beispiel / Stillstand des Bandes.
 Zum Beispiel / Anwendung eines 97°-90°-Maschinen mit der Teleskopspindel.

In the hold up position you must mount the hard-metal-segments with an angle of 97° to the belt. Afterwards you can change the force with the telescopes.

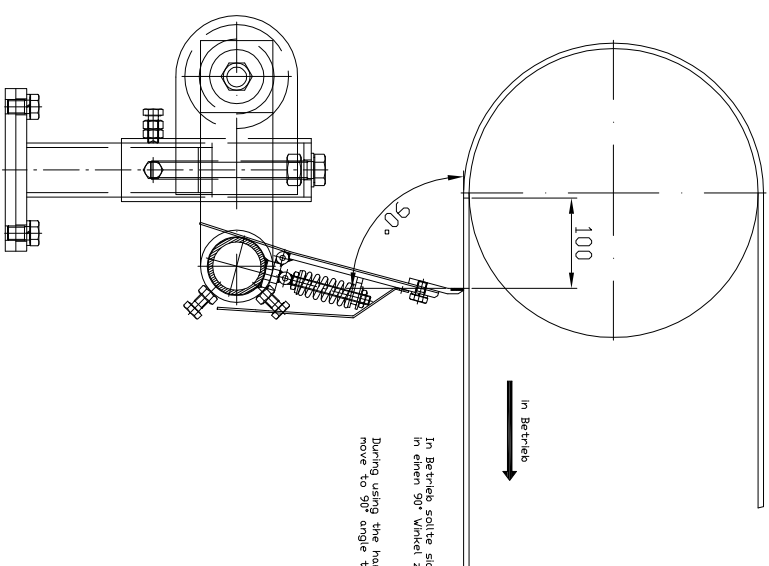

In Betrieb sollte sich die Hor-thetall-Segmente in einem 90° Winkel zum Gurt ziehen.
 During using the hard-metal-segments shall move to 90° angle to the belt.

		Scale,	./.	
2014	Date	Name		
edited.	28.07.	Paschen		
tested				
Norm.				
Drawing-no				
637-1400-07/02				
		<p>Technische Änderungen vorbehalten technical changes reserved</p>		
		<p>T.I.S. Dr.ITSchland</p> <p>Abstreifsysteme & Förderbandzubehör</p>		
		<p>Installation Elso tol-Hor-thetall-Segmentabstreifer NEU mit Federn</p>		
		<p>Art.Nr. 1400E37-FE</p>		